

TECHNICAL ASPECT OF CAD AND BIM TECHNOLOGY IN THE ENGINEERING ENVIRONMENT

MATEA RISTEVSKI^a, MIRKO KARAKAŠIĆ^b, IVAN GRGIĆ^c and DUBRAVKO
ŠOTOLA^d

^aStudent Mechanical Engineering Faculty in Slavonski Brod, Trg Ivane Brlić-Mažuranić 2, 35000 Slavonski Brod, Croatia.

^bAssociate Professor Mechanical Engineering Faculty in Slavonski Brod, Trg Ivane Brlić-Mažuranić 2, 35000 Slavonski Brod, Croatia.

^{c,d}Mechanical Engineering Faculty in Slavonski Brod, Trg Ivane Brlić-Mažuranić 2, 35000 Slavonski Brod, Croatia.

Abstract: The paper presents advantages and disadvantages of CAD and BIM technology in the engineering environment. Specific attributes of these technologies have been compared to gain the sense of what they represent in the design and planning process. Through the practical design of the project of the cogeneration plant block, it was noted that CAD environment is more acceptable in the detailed design process. On the other hand, BIM environment, compared to CAD, is less flexible in the process of detailed design but provides a more complete data model at the level of the entire product development process.

Keywords: Building Information Modeling (BIM); Computer Aided Design (CAD); Design process

1 INTRODUCTION

Building Information Modeling (BIM) is a technology that aims to build up a rich computer model that forms the basis of the planning process. Using BIM technology leaves the traditional approach to planning, which has the effect of reducing expensive changes to the project, reducing the need for changes and re-use of data needed to manage and maintain the construction [1]. It is a process that follows the construction from the idea until the moment of exploitation and maintenance process. According to [2], it is possible to describe the BIM process as in Fig. 1.



Figure 1 BIM process

With the development of computer technology, CAD systems expand from 2D to 3D computing space. Thus, two-dimensional models replace space models that make up the core of BIM technology. This model complements, in the BIM environment, the following data: geometry, costs, time, sustainability, energy consumption, management and maintenance [1].

The reason why CAD systems complement BIM systems stems from the fact that CAD is highly specialized in the design process (particularly detailed design stage) and with its capabilities does not fully integrate the need for a wide spectrum of data processing resulting from the product development process.

BIM as a technology has its own development process consisting of four levels [2]. The zero level represents the period in which 2D CAD systems were used. Communication between project participants was done with paper and electronic. The first level represents the period in which 2D and 3D CAD systems are combined. There is no clear communication between the project teams. The second level uses 3D CAD systems. Communication between project teams takes place using neutral file formats (IFC formats). The third level represents the integrated work of project teams through a common project model located in a common information environment. This type of work is called "Open BIM".

2 COMPARISON BETWEEN BIM AND CAD TECHNOLOGY

Computer Aided Design (CAD) is a technology that uses computer application in the design process and production of technical documentation. The first CAD systems were oriented only to the two-dimensional drawing, i.e. making technical documentation [3]. During the '60s and early '70s, demands for the expansion 2D CAD systems were introduced with the inclusion of a third dimension [4].

Today's application of feature-based parametric modeling CAD systems that use solid bodies is manifested in the creation of 3D models, technical documentation, geometry definition, analysis using Finite Element Method (FEM) and creation of Computer Numeric Control (CNC) programs. In addition, using 3D solid models is the basis for the development of PDM, ERP and BIM systems. These systems generate intelligent data models (information models) that use 3D models as the basis. This approach gives its users (engineers and architects) opportunities and insights for more effective planning, design, building and project management [1]. Information model, designed by BIM technology, contains the visual 3D model display, geodetic coordinates, material type, material amount, geometric properties, costs, physical properties, etc. This model contains product information from its idea up to recycling.

There are numerous software packages that use BIM technology, such as Autodesk Revit [5]. Since such program packages are extremely expensive, complex and require a certain time to adapt to work in them, their integration into the CAD software package is realized. These solutions make it easier for users to work with BIM because of the already established work in the familiar programming environment.

The application of BIM technology in the modern product development process has many advantages: increasing productivity up to 40%, increasing competitiveness, increasing project quality, using a centralized shared model, and using a single platform which reduces the risk of data transmission errors [1].

3 BLOCK OF THE COGENERATION PLANT

This chapter presents a brief overview of the process of making a 3D model of piping with equipment and armature in accordance with the European norms within the CAD and BIM environment. Model was created according to the process shown in Fig. 2. For the design of the project in CAD environment, the AutoCAD Plant 3D software was used, and Autodesk Revit [5] was used for its design in the BIM environment.

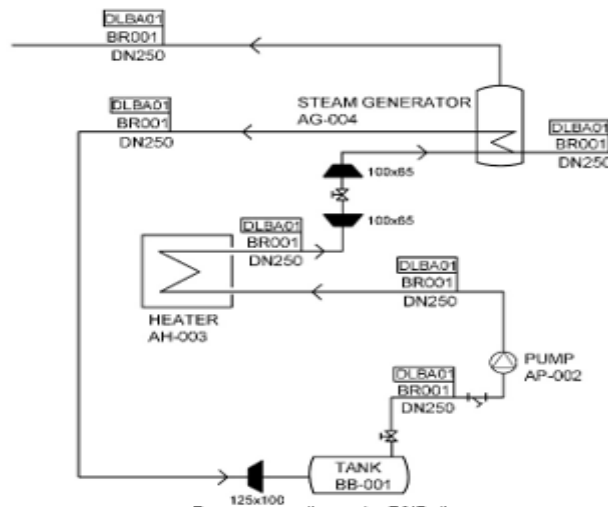

Figure 2 Process according to the P&ID diagram

3.1 Project Design in CAD Environment

According to the P&ID diagram, the project involves defining and installing the following equipment in the AutoCAD Plant 3D model space: block valve – DN100; tank - capacity 600 l, nominal pressure PN16, DN100/DN125; centrifugal pump – capacity 0.3-1 m³/s, DN65/DN100; booster water heater – DN65 input/output and water vapor generator – DN250 output. Equipment marks correspond to the KKS system [6] and to the specification supported by the AutoCAD Plant 3D.

Modeling process begins with the generation of pipeline armature, using predefined conceptual models in the 3D Piping module. When integrating P&ID diagram into a 3D model, the P&ID Line List is used. By applying such specialized modules within CAD, it is possible to provide a reliable and quick project pipeline design with predefined components and their properties. Block valve DN100 is not a part of Plant 3D; therefore, it is inserted as a block from [7] in a suitable format. Valve is parametrized and it is possible to generate its families, depending on the pressure values and other design parameters (Fig. 3).

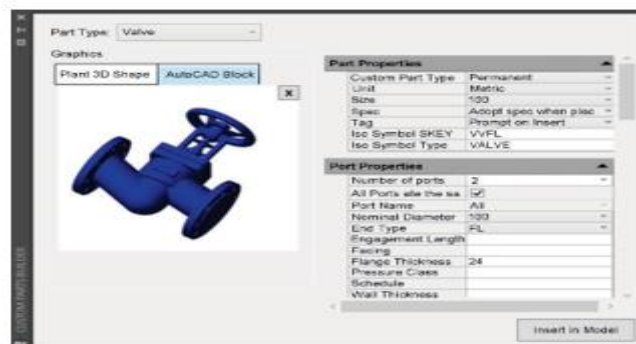

Figure 3 3D block of valve

Tank needs to be dimensioned according to the measurements shown in the Fig. 4. Equipment needs to be placed according to Fig. 5.

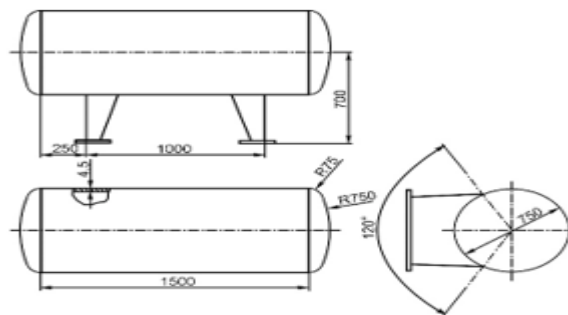

Figure 4 Tank dimensions

Piping identification was performed according to the KKS marking system [6]. In addition, the identification was done according to the Plant 3D specification.

Block valves DN100, KKS marks DLAB01AA001 and DLAB01AA003, are positioned upright (Fig. 6a) and the actuator is directed upward because both piping sections are low enough. In this way, it is possible to operate the actuators smoothly. Arms are also marked with the KKS marks. Fig. 6b shows the arm of steam line whose dimensions are DN250. KKS mark is DLBA01BQ001/2. The final 3D model of the pipeline with equipment and armor made in AutoCADPlant 3D is shown in Fig. 7.

Matea RISTEVSKI et al.: TECHNICAL ASPECT OF CAD AND BIM TECHNOLOGY IN THE ENGINEERING ENVIRONMENT

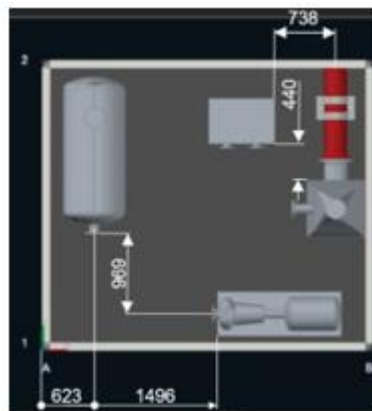

Figure 5 Disposition of equipment in model space

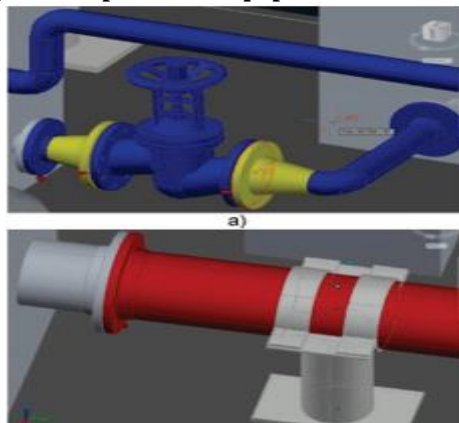

Figure 6 Block valve DN100 and steam line arm DN250



Figure 7 Block of cogeneration plant modeled in AutoCAD Plant 3D

3.2 Project Design in BIM Environment

Pipeline project was developed with Autodesk Revit, i.e. P&ID Modeler module. This module allows creation of 3D pipeline models from 2D P&ID .*dwg* drawings. It is possible to share drawings using the BIM 360 Team service. Main features of the BIM 360 Team are that it combines files and project information, enables data sharing among project team members, review of 3D models and 2D drawings, and allow tracking of workflow on project.

The equipment is placed in workspace with the P&ID Modeler. Also, it is possible to see information that is part of the BIM process description (Fig. 8).

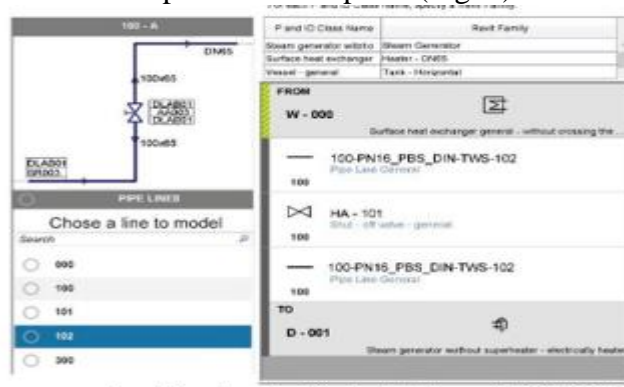

Figure 8 Status information and modification of pipeline model DLAB01BR003

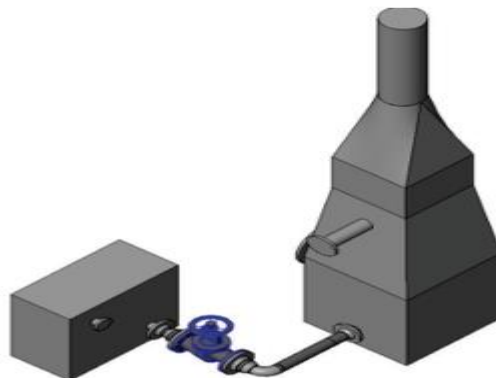

Figure 9 3D model of pipeline DLAB01BR003

Pipeline DLAB01BR003 contains block valve and concentric reducers (Fig. 9). It is necessary to model and place Steam line arms DN250 (Fig. 6b) in the piping model. This is Revit's shortcoming, because there is no fully defined component base. In this way, the duration of the design process is extended.

During Revit production of technical documentation, the pipeline isometric overview is a problem. Revit is extremely weak, and some of its disadvantages are impossibility of connection elements with 3D model, complex dimensioning, a modest symbol base, symbols are appropriated for 2D description, and the workspace is open. Fig. 10 shows the drawing of pipeline part in isometry.

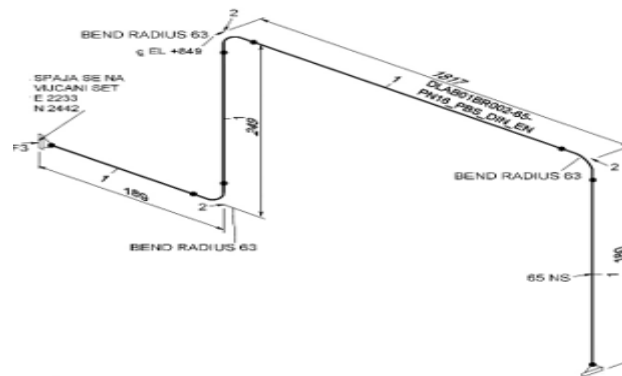

Figure 10 Part of pipeline modeled in Revit

4 CONCLUSION

BIM technology is rich with the information and follows the product development process from the beginning (concept) to the end (recycling). In the case of specific projects, such as the process industry pipelines, CAD is significantly ahead. Reasons lie in advanced modules that are more adjusted to a particular area. During the production of technical documentation and isometric representation of the pipeline model, Revit showed some limitations regarding Plant 3D.

CAD tools (such as AutoCAD Plant 3D) are more complete for pipeline engineering. The disadvantage is obvious in the view of a complete data model, which lacks information that is not related to the design process.

Taking into account the time required for project development, due to good and high quality preparation, AutoCAD Plant 3D proved to be a more flexible platform than Revit. The reason lies in the fact that at the beginning of the project the equipment is directly made in Plant 3D and in this way enables it to adapt to the further needs of the project. In Revit, however, such a step requires adaptation of existing families, i.e. the creation of new components of the plant.

References

1. Jurčević, M., Pavlović, M., & Šolman, H. (2017). Opće smjernice za BIM pristup u graditeljstvu. Zagreb, Hrvatska: Hrvatska komora inženjera građevinarstva.
2. <https://www.intelika.hr>
3. Kyran, M. D. (1997). The CRC Handbook of Mechanical Engineering. New York.
4. Bojčetić, N. (2001). Računalni model konstrukcijskog znanja. Zagreb, Hrvatska: Fakultet strojarstva i brodogradnje.

5. <https://www.scribd.com/document/322721362/Revit-2014-Prirucnik-Za-Pocetnike-PP>
6. Kim, J. Y. (2012). Procedure for plant identification (KKSnumbering system).
7. <https://www.ari-armaturen.com>